



TITAN

Titan Downdraft Paint Booth



REFINISHING SOLUTIONS FOR EVERY SHOP

SAIMA of North America Inc. | Randolph, New Jersey 07869 | 800.524.0340
info@accudraftpaintbooths.com | www.accudraftpaintbooths.com



TITAN



Titan Downdraft Paint Booth

The Accudraft Titan™ is the ultimate in spray booth technology and high speed finishing production. Airflow and workspace conditions are engineered and optimized for the latest low VOC & waterborne paints on the market today.

Unmatched downdraft airflow and contamination control produce fantastic jobs faster, while EnergySmart™ technology saves you time and up to 50% on energy costs.

The TITAN™ uses dual mode technology allowing the system to switch between water-based or solvent-based modes on the fly, making you able to paint today while being ready for tomorrow.

Includes Accudraft LIVE control panel & 1 year of Accudraft LIVE free



accudraftLIVE



Since 1977

SAIMA

Insulated Simple Joint Construction

Interlocking Panel System

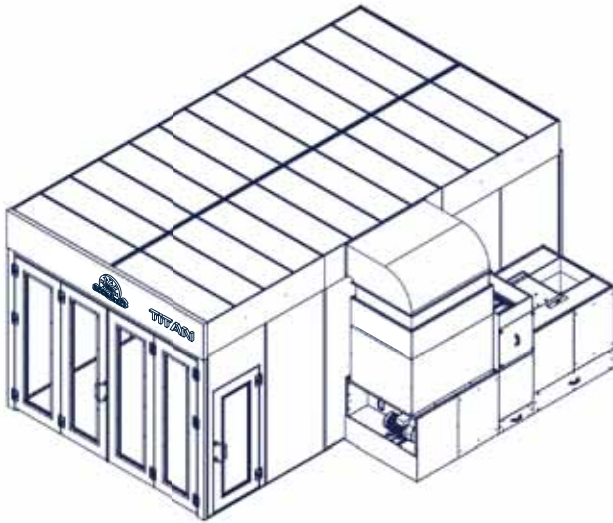

Accudraft TITAN Spray Booth
& KD-560/630R Mechanical Group

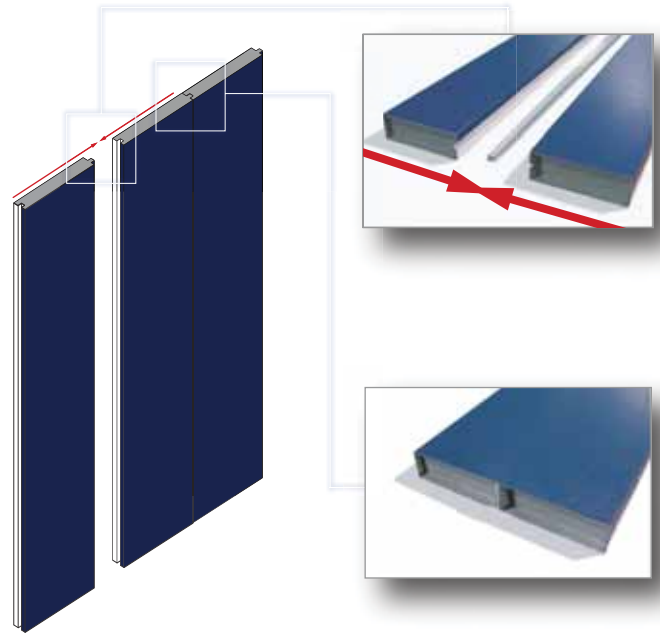

The tongue & groove interlock system creates a workspace with up to four times the integrity of ordinary spray booths. Galvanized steel and industrial PVC coatings provide the highest grade of durability and outdoor weather resistance available. The tongue & groove panel design also produces a neat & clean finish free of bolts or screws.

Exterior



- Textured Vinyl Exterior
- Galvanized Steel
- Non-flammable Insulation

Interior



- Ultra- White Non-Reflective Vinyl Interior

Industrial Vinyl Coating

Interior & Exterior

- Galvanized Steel
- Chemically Bonded PVC Coating (Interior & Exterior)
- Manufactured & Shipped with Protective Polyethylene Coating
- 24 Inch Interlocking Male & Female Panels
- Insulated Dual Skin Construction
- Non-flammable Insulation
- Meets National Fire Protection Requirements (NFPA Compliant)

Available Exterior Colors:



Accudraft Blu™



Ultra White™



Furia™

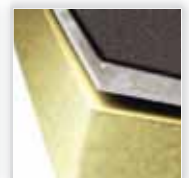

Grigio™

Workspace Lighting

Daylight Corrected Illumination

- Color Correct LED lighting
- Shadowless Lighting Design
- 45° Inclined Upper Light Banks
- 48" Vertical Wall Lights (recessed)
- (23) Four-tube Light Fixtures Total*

*At standard sizes



(10) 45° Upper Gable Lights
(Standard)

(13) Recessed Vertical Wall Lights (Standard)



Lab certified explosion proof light fixtures protect against potentially explosive materials. Inside accessibility allows easy tube changes from inside the workspace. If a light door is open, the light fixture will automatically shut off the user's spray gun to prevent any potentially hazardous fumes from being introduced while the fixture is being serviced. Inside accessibility also allows for more installation flexibility. The system can be installed in a shop corner or up against existing structures since space is no longer needed to access the outside of the light fixture.

◀ MAGNA II Explosion Proof Light Fixtures

- Vinyl Coated
- Hinged Inside-Access Glass Lenses
- T-8 Energy Efficient Bulbs Included
- Daylight Corrected for Superior Color Matching
- Lab Certified Explosion Proof (Class I : Div. II)
- ETL Listed

Ceiling Filtration ►

- 5-Micron Downdraft Diffusion Ceiling
- Full Width Ceiling Filtration
- EZ-Clip Change Out System



▲ EZ-Clips

Tools Free Ceiling Access

EZ-Clips allow for fast and tools-free ceiling filter changes. Changing ceiling filters can be completed in less than 30 minutes and can be performed by one person.



Airflow Pattern ▲

Full width ceiling filtration provides a proper downdraft envelope around the vehicle. Ceiling air reaches all areas of the workspace and flows toward the exhaust point underneath the vehicle. Walls and lights are kept clean by the wide downflow pattern and the extended pit

EvenFlo™ ►

Downdraft Balancing System



Adjustable Vanes ▲

Re-adjustable Microtag Winglets

EvenFlo™ downdraft balancing vanes allow the Titan to draft evenly across the entire exhaust pit or basement. No more uneven drafts or dead spots. Each vane is attached by flexible microtags that allow the user to adjust and readjust multiple times if changes are needed.

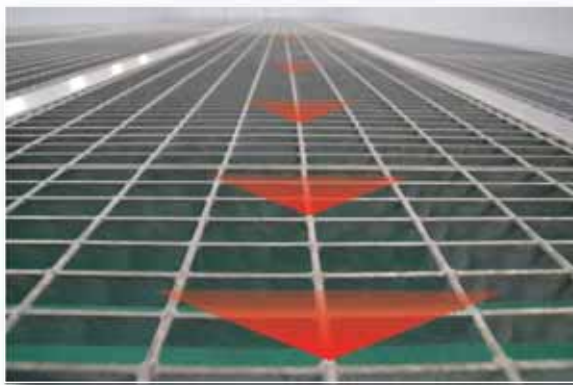

Vertical LED Light Fixtures

- (23) Fixtures
- 48" Long
- 4 tubes each
- Inside access

ETL lab-certified explosion proof.



Smooth Glide Hinges

Industrial nylon axis. (6) Nylon isolation bushings per hinge. Includes personnel door.

LIVE Controller™

Touchscreen controller with ability to hold 999 user-programmed settings for spraying.



Accudraft LIVE™

Accudraft LIVE is a mobile-friendly, cloud-based solution for monitoring your paint booth's performance, cost, and technical metrics.



Tempered Glass Windows

Standard on all Accudraft Titan door assemblies



Recessed Door Hardware

Locking mechanisms are built into each door, ensuring a proper closure. Recessed handles and integrated door hardware provide a neat and clean appearance free of bolts & bars. Wire mesh reinforced glass provides added strength & durability on all observation windows including personnel access door, drive through doors, & optional 6-door side-entrance doors.



EZ-Clip Ceiling Filters

No more time consuming filter changes. EZ clips & hinged filter frames make filter changes a quick and simple process.



Superior Ceiling Filtration

5 Micron air quality. Perpendicular compression edges are built into each filter frame for a continuous seal around each filter.



Insulated Dual Skin Construction

Galvanized steel with bonded PVC exterior and interior.

Available Exterior Vinyl Colors:

-  Accudraft Blu™
-  Furia™
-  Ultra™ White
-  Grigio™

EvenFlo™ Downdraft Balancing System

EvenFlo™ adjustable floor vanes allow the user to pinpoint areas of more or less air flow and adjust the strength of the draft until it is just right.



EnergySmart™ System Included

(2) 15 Horsepower VFD's & up to 50% energy savings



20,000 CFM ▶ (2x) 20,000 CFM Belt Driven Centrifugal Fans

- Backward Inclined Exhaust
- Forward Curve Intake (Reduces Noise in the Workspace)
- Non-Sparking (Certified for Hazardous Location)
- Greasable Pillow Block Bearing Mounts



Bearings ▶ Superior Strength & Durability

- Encapsulated Ball Bearing Design
- Designed for High Temperatures
- Easily Accessible Grease Fittings



▼ (2) 15 HP Motors Weg® NEMA Premium Efficiency Motors

- (2x) 15 HP TEFC Motors
- Fan Cooled Cast Iron Body
- Re-greaseable Ball Bearings
- 3 Phase 240V or 480V
- Rated for Continuous Operation
- Designed for Dusty Environments



20%



20%



Want More?

The Accudraft TITAN is also available with:
Timeless™ Direct Drive Mechanical Group

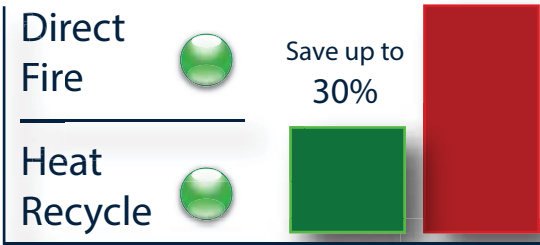

All cost values & references are estimated and are not guaranteed. Actual operating costs may vary.

◀ Clean & Energy Efficient

Pre-filtration, Re-filtration, Post-filtration

- Pre-filtration (Accepts Flat Insert or Bag Filtration Media)
- Post-filtration (Accepts Flat Insert or Bag Filtration Media)
- 80-90% Heat Recycle
- Includes Recycling Stage Re-filtration

When compared to basic heated spray booths, the Titan can use up to 30% less energy. Integrated heat recycling connects intake and exhaust in one compact unit and provides the highest form of heat efficiency possible. Direct fired heat gives the KD mechanical group up to 99% fuel efficiency. This means that almost 100% of the gas being used is actually turning into heat. No more inefficient fume chimneys or heat exchangers and no more high/low temperature swings. The direct fire burner maintains an open flame and increases or decreases the flame's intensity depending on the temperature setting. Maintainable temperature accuracy can approach $\pm 1^{\circ}\text{F}$.

Extra large motors and turbines allow the KD mechanical group to move a large volume of air. Two 15 Horsepower Weg* motors generate powerful airflow at a rate of up to 20,000 CFM. This means that the entire cubic volume of the Titan's workspace is exchanged almost 6 times every minute.* Once a vehicle or large body is introduced to the workspace, the volumetric air exchanges become even faster.

Three stages of filtration (prefiltration, post filtration, & recycle filtration) provide an ultra clean spray environment and protect the life of fans & mechanical components from overspray and dust.

*Volumetric exchanges based on Titan starting size (28'x14'x9') (LWH)



Burner ▶

- Computerized Burner Controls
- Direct Fire - 99% Heating Efficiency
- 1.5 Million Btu/hr (1.5 Million+ available)
- Stainless Steel Burner Construction
- Natural Gas or Propane Fuel



Work Phase ►

Prep, Spray, Flash

The Titan provides a clean and comfortable work environment during the work phase. The user can prepare the job, mask, apply coatings and flash off during this phase. The mechanical group performs at full power, providing a strong downdraft and positive pressure. This ensures a clean workspace by pushing dust and dirt away from doorways & seals. High speed airflow provides fast overspray removal and produces short flash times between coatings.

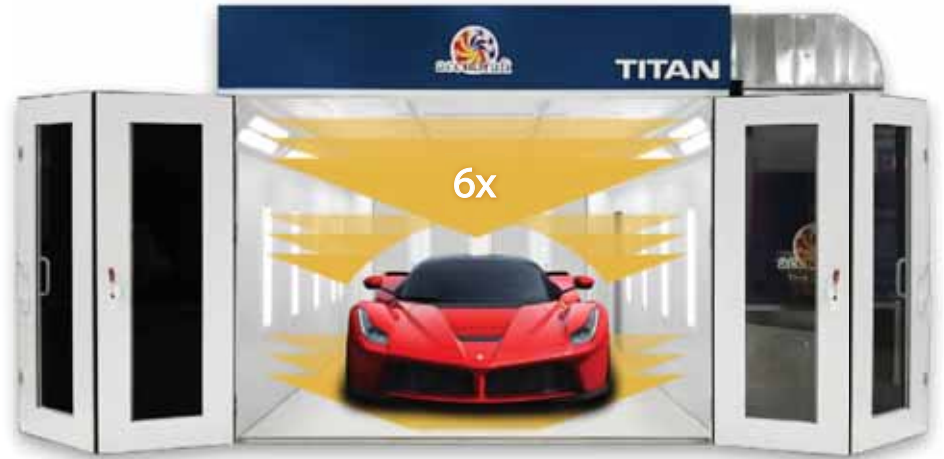

◀ Cure Phase

High Temperature Drying



During the cure or "bake" phase, air is heated to the coating's recommended curing temperature. Air is recycled past the burner for heating speed and maximum efficiency. The curing phase is divided into two distinct processes. The first is a pre-heating process that introduces extremely hot air to get the metal or substrate to the proper temperature. Once that temperature is reached, a lower secondary temperature is maintained.

Cool Down ►

Cools & Hardens

Technically the final stage of curing, the cool phase brings the coating and substrate temperature down to further solidify and harden the coating. Cooling is essential to good finishing and the workspace must be cooled in order for the user to work comfortably on the next job. With about 6 exchanges of air every minute, the Titan cools very quickly and keeps jobs moving fast.



LIVE Controller & Accudraft LIVE™ ▼

- Remote login and diagnostics
- Analytics
- Costing

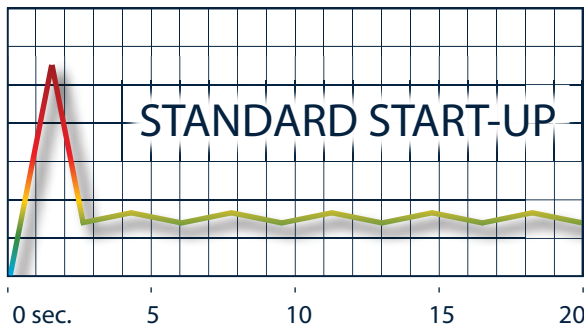

Amps

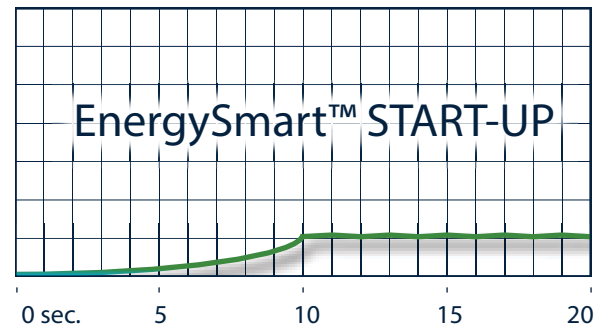

Standard Start-Up ▲

Traditional motor start-up causes a spike in power draw. Most utility companies charge a service factor and rate the facility according to the highest possible power draw.

For example: Motors that are rated for 25-30 Amps of running power may spike to over 100 Amps momentarily as the turbines wind up from a standstill. After a few seconds, the power draw levels out, but the damage has been done. The shop will now be charged according to the "spike" rate, not the lower running rate.

EnergySmart™ Start-Up ▲

With Accudraft's EnergySmart™ Feature, motors are gradually started in order to get the turbines spinning. Each VFD drive continues to increase each motor's speed until the proper amperage is reached. This eliminates the spike in power and can save 30% or more on electrical usage.

The SmartPad™ digital control panel gives the EnergySmart™ system two additional functions. First, the VFD drives automatically maintain pressure inside the spray area by adjusting turbine speeds accordingly. Second, the drives drop all motors to idle when the spray gun is not in use. This allows the system to run at full power only when the user is spraying and can save thousands in energy usage over the course of a year.



◀ EnergySmart™ VFD

Variable Frequency Drive System



- Save 30% or More on Electric Usage
- Automatic Pressure Control
- STANDBY Feature - Drops system to idle state when not in use
- Max quality for government energy rebates*

* All regions may not qualify. Rebate percentages may vary

Superior Build Quality ▶

Welded Structural Steel

- Welded steel door frames
- No flimsy sheet metal parts
- No field work or fabrication required by installers

Welded Upper Threshold Supports ▼



Welded Personnel Access Door Frame ▼



Welded Main Tri-fold Entrance Door Frame & Hinge Plate ▶



▼ A Bit of History

The Crossroads of Technology and Old-World Craftsmanship

Accudraft's signature structure has been a symbol of its unparalleled quality for over 35 years. Build quality is the cornerstone around which all Accudraft products are engineered, and it's place stems from the origins of the company itself.

Accudraft products originated near the town of Arezzo, a region in Italy known for its artisan or "artigiano" roots in metalworking. During industrialization, local craftsmen brought their passion for superior quality to the foundries and industrial factories. Whether the finished product was an industrial machine or a piece of jewelry, the end result was a high level of quality that people could see and feel. This became the cultural signature of the region and back in 1977, it ended up shaping every step of production on the first ever Accudraft spray booth.

After more than 35 years, each main door assembly is still individually test mounted in the factory before it is dismantled, crated, and shipped.

Superior Build Quality

Heavy Duty Hardware



(6x) Super Duty Nylon Sheaves ▲

◀ Nylon Axis Hinges

Heavy Duty Capacity. Easy Operation

- Nylon on Nylon Isolation Bushings
- Smooth Swinging Motion
- Maximum Durability
- Hardened Fasteners
- Threaded Plate Steel Supports

Accudraft's welded steel door structure, internal lock mechanics, and wire-mesh reinforced glass windows create a very rugged door system, and nylon axis hinges allow them to be swung with the touch of a finger. For the user, operation is light as a feather and doors can be fully opened in a matter of seconds. All rotation points are engineered using nylon bushings, giving the doors an unmatched lifespan. Doors will open thousands of times over decades of use before any bushings need replacement.



◀ Integrated Door Seals

Built-In Door Locking Mechanism

- Integrated Dead Bolts
- Factory Tight Doors
- Flush Mount Red Handles
- Neat & Clean Finish

Internally constructed door lock mechanisms provide proper closure. Lesser systems provide rods mounted on the outside of the door panel with simple straps or bars. Accudraft's integrated red handles ensure that the user cannot tamper with the door's integrity and it also ensures protection from overspray and damages caused by vehicles or tools bumping into the locking mechanism. Deadbolts have pre-punched slots in the upper and lower threshold to ensure the doors are closing properly.



Upper Deadbolt ▲

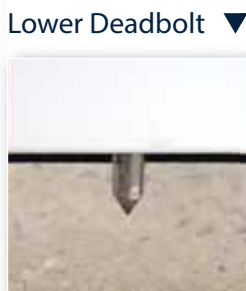

Lower Deadbolt ▼

Superior Build Quality

Heavy Duty Hardware



◀ Easy Grip Handles

Oversized Heavy Duty Steel Handles

- Formed Tubular Steel
- 1/8" Welded Anchor Plates
- Extra Large Size for Easy Grabbing
- Ultra-White Powder Coated Finish



Nylon Roller Catches ▼

Accudraft spring latches are designed to release in the presence of sudden over-pressurization of the workspace or in the event of an explosion. Elongated fastener slots and adjustable spring tightness allow for proper alignment between male and female pieces. Nylon lined rollers prevent wear over thousands of trips in and out of the work area and provide a smooth, quiet operation. No loud clangs or bulky refrigerator-style latches to slam open and shut. A simple click and a thump lets the user know the door is properly shut.



→ $F = -kx$



Product Comparison Chart ▼

2001™ Series

Features	SS (Space Saver)	ITALIA	TITAN
Dual Skin Type	Simplejoint	Simplejoint	Insulated Tongue & Groove
Airflow CFM	Up to 14,000	Up to 14,000	Up to 20,000
Draft Pattern	Semi Downdraft	Downdraft	Downdraft
Standard Mechanicals	Space Saver AMU	Timeless	KD-560/630R
Drive Type	Belt Driven	Direct Drive	Belt Drive
Intake HP	10 HP	10 HP	15 HP
Exhaust HP	10 HP	10 HP	15 HP
Heating Power	1,200,000 Btu/hr	1,200,000 Btu/hr	1,500,000 Btu/hr
Heat Recycle	0 - 80%	0 - 80%	0 - 80%
Fixture Size / Tubes	48 Inch - 4 Tube	48 Inch - 4 Tube	48 Inch - 4 Tube
Lighting Power (W)	128 Watts / Fixture	128 Watts / Fixture	128 Watts / Fixture
LED Upper Angled Lighting	10*	10*	10*
LED Wall Lighting	13*	13*	13*
Fixture Orientation	Vertical	Vertical	Vertical
Ceiling Filter System	Full Width - 5 Micron	Full Width - 5 Micron	Full Width - 5 Micron
Ceiling Filter Access	EZ-Clip	EZ-Clip	EZ-Clip
Waterborne	Add Xcelerator™	Add Xcelerator™	Waterborne Ready
Controls	SmartPad™	SmartPad™	Accudraft LIVE™
EnergySmart VFD's	EnergySmart™	EnergySmart™	EnergySmart™
Starting Length (ft)	24	24	28
Starting Width (ft)	13	13	14
Starting Height (ft)	9	9	9
Exterior Vinyl Colors			

* Quantities may change if workspace length is extended or reduced.



Worldwide Automotive Finishing Products



35

YEARS

SAIMA of North America Inc. | Randolph, New Jersey 07869 | (800) 524-0340
info@accudraftpaintbooths.com | www.accudraftpaintbooths.com

SAIMA Of North America

Scan
QR Code



© 2013 SAIMA of North America Inc. All rights reserved.
® Accudraft is a registered trademark of SAIMA of North America.

The information contained herein is general in nature and is not intended as a guide to perform work/design of any kind.